

BG-subMIDI multi-purpose horizontal electrophoresis system user manual

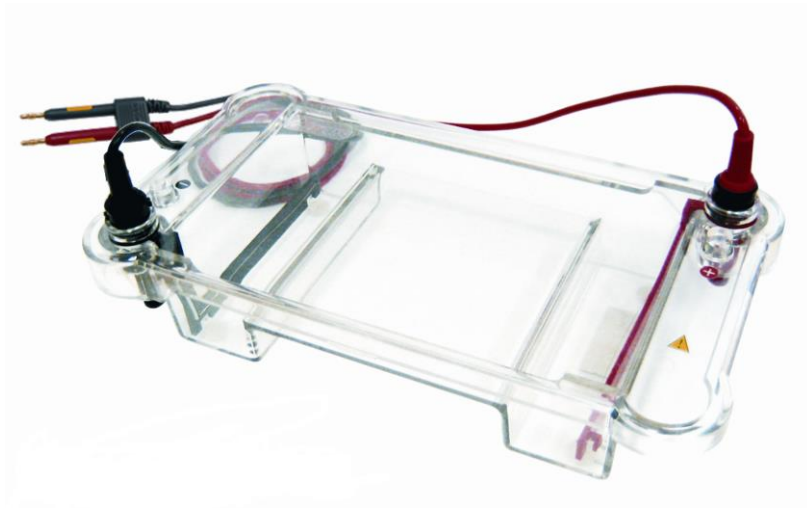

Executive standard: GB/T 29248-2012

Product Record: Jingshun Machinery Equipment 20140002

Beijing Baygene Biotech Company Limited

CONTENT

CHAPTER I PRODUCT INTRODUCTION.....	1
1.1 INTRODUCTION	1
1.2 STRUCTURE AND COMPOSITION	1
1.3 THE MAIN TECHNICAL PARAMETERS	2
CHAPTER II OPERATING PROCEDURES.....	3
CHAPTER III CARE AND MAINTENANCE	4
CHAPTER IV TROUBLESHOOTING.....	4
CHAPTER V TRANSPORTATION AND STORAGE	6
CHAPTER VI WARRANTY	7

Important safety information!

Please read carefully before use!

This manual contains important operational and safe use information! In order to use this instrument better, please read the contents of this manual carefully before use!

To avoid the risk of electric shock when the instrument is not in use, disconnect the instrument from the power source. The power supply should also be in a power down state. Before use, please check the outer tank for cracks to avoid leakage of buffer from the crack during electrophoresis, resulting in electric leakage. In addition, please check the wire and plug for loose connection, broken rubber, wire corrosion, wire disconnection, etc., so as to avoid harm to the human body during use. The instrument is intended for use only for the purposes described in this manual. Do not continue to use this product if the wire or instrument is damaged. Please disconnect the power when moving the product. When electrophoresis, inspect the base and workbench of any signs of buffer leakage. If leaking buffer is detected, disconnect the power immediately and contact our company or local office.

Note: The company is not responsible for any consequences caused by not following the instructions.

Chapter I Product Introduction

1.1 Introduction

The BG-subMIDI multi-purpose horizontal electrophoresis system is mainly used for agarose gel electrophoresis of DNA and RNA. Special gel caster and free combination of various specifications trays make it easy to use. A gel tray with a fluorescent ruler is convenient for observation. The tray has a patented ear structure which is for easy handling. The gel can be loaded with multi-channel pipette. 96-well PCR sample electrophoresis experiments are available (optional). The instrument mainly includes gel tray, lower tank, upper tank, gel caster and comb, etc. It can carry different sizes such as 6×6 cm, 6×12 cm, 12×6 cm, 12×12 cm, and different sample amounts of gel electrophoresis.

The BG-Power600/600i/300 provides the power required for the BG-subMIDI multi-purpose horizontal electrophoresis system.

1.2 Structure and composition

After purchase the instrument, please check the accessories on the packing list before use and check if the instrument is damaged due to transportation. If the number of accessories is more or less than that noted on packing list or the instrument is damaged, please contact the company or local office immediately. When unpacking, use a knife to cut the packing tape gently and take out the instrument.

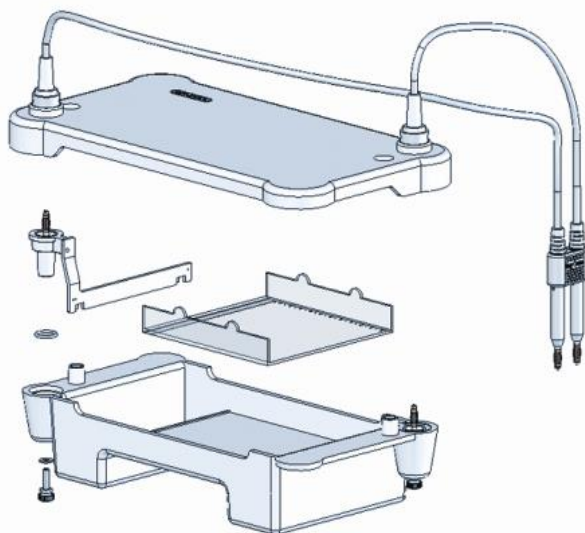

Fig. 1 Main components

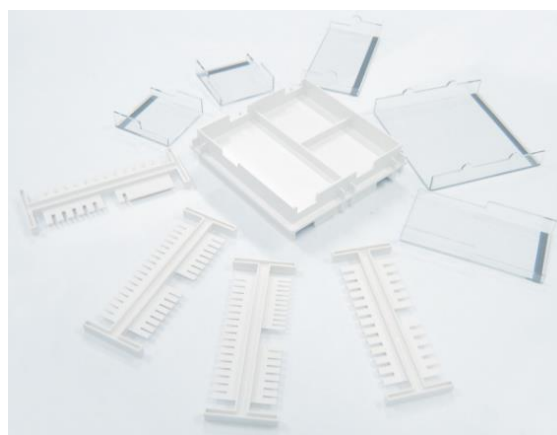

Fig. 2 Gel caster、 gel casting tray and comb

The packing list is as follows:

Accessories	Number	Accessories	Number
Main tank	1	Top lid and power cord	1 set
Replaceable electrode	1 pair	Gel Caster	1
Gel casting tray	5	Comb	6
	12×12 cm, 1		comb A (1.5mm,2+6/13 well)
	12×6 cm, 1		comb B (0.75mm,6+6/13 well)
	6×12 cm, 1		comb C (1.5mm,8+8/18 well)
	6×6 cm, 2		comb D (0.75mm,8+11/18 well)
			comb E (1.0mm,11+11/25 well)
			comb F (2.0mm,3+3/2+3 well)
Manual	1	Warranty Card	1
Certification	1		

1.3 The main technical parameters

Size	300×165×118mm
Tray Area (W*L)	Standard: 12×12cm, 12×6cm 6×12cm, 6×6cm Optional: 96-Well PCR Electrophoresis Package (12×12cm Tray: 1, Comb E(1.0mm,11+11/25 Well) 4, Comb F (2.0mm,3+3/2+3 Well): 4)
Comb	Comb A (1.5mm,2+6/13 Well)
	Comb B (0.75mm,6+6/13 Well)
	Comb C (1.5mm,8+8/18 Well)
	Comb D (0.75mm,8+11/18 Well)
	Comb E (1.0mm,11+11/25 Well)
	Comb F (2.0mm,3+3/2+3 Well)
Number of gels that can be made at the same time	1-3
Max Volume of buffer solution	800ml
Weight (net weight)	1.16 Kg

The power required for the instrument to work is DC power. The maximum power parameters of the instrument are as follows:

Max. voltage	200V
Max. power	40W
Max. buffer temperature	40 ° C

Chapter II Operating Procedures

1. Place the gel caster on a horizontal table, then place the gel casting tray in the corresponding grid of the gel caster and the comb in the slot. According to the demand, four size of gels, 12×12cm, 12×6cm, 6×12cm and 6×6cm, can be made using the gel caster.
2. Prepare a suitable agarose solution with electrophoresis buffer according to the size of the isolated DNA fragment: accurately weigh the agarose dry powder into the flask or glass bottle containing the quantitative running buffer. After stir with a glass rod, put the flask or glass bottle in a boiling water bath or microwave to heat the agarose to melt. (The agarose gel concentration recommendation table is detailed in the attachment.)
3. After the gel is slightly cool, pour the gel into the tray slowly. Recommended thickness of gel is 3~5mm (note: there should be no bubbles in the gel).
4. Waiting 30 to 45 minutes to allow the gel to completely condense. Carefully pull out the comb and place the gel in the electrophoresis tank with the side of the sample well near the cathode (black end).
5. Add the running buffer to the electrophoresis tank, at least 2mm over the gel. (Note: TAE buffer needs to be replaced after 2 or 3 times, and TBE buffer can be used about 10 times.)
6. Mix an appropriate amount of DNA sample with 6× loading buffer (added nucleic acid dye) and then load the sample with a pipette into the sample well. Be sure load the appropriate DNA molecular weight marker in the left or right well of the sample well.

Note: when analyze a single DNA sample, such as L phage or plasmid DNA, add 100-500 ng of DNA per 5 mm wide well. If the sample consists of many DNA fragments of different sizes, such as mammalian DNA digestion, add 20-30 µg of DNA to each well.

7. After sample loading, place the lid on the electrophoresis tank and connect the electrophoresis power supply. A voltage of 5 to 8 V/cm is applied (the distance is measured between the anode and the cathode). The anode and cathode will generate bubbles due to electrolysis. DNA should move toward the anode (red plug) side. The choice of electrophoresis time depends on the length of the gel, the voltage and the size of the DNA fragment. The longer the gel, the lower the voltage, and the larger the DNA fragment, the longer it

takes. However, when high voltage is used, the resolution of large DNA fragments will be low and the bands not clear. (The gel voltage per cm does not exceed 8V. If the voltage is too high, the resolution will decrease. The electrophoretic mobility of the linear DNA molecule is proportional to the voltage used only when low voltage.)

8. After the electrophoresis is completed, remove the gel and observe or photograph it in an ultraviolet analyzer or gel imaging system.

Chapter III Care and Maintenance

1. The temperature (normal ambient) is between 4°C and 40°C with humidity levels no more than 95%. Install the product in. The temperature (normal ambient) is between 4°C and 40°C with humidity levels no more than 95%. Install the product in a well-ventilated room with no corrosive gas..
2. After using the instrument, carefully clean the gel tray, lower tank, gel caster and comb with a mild detergent.
3. If the electrode tip gets wet, dry it with absorbent paper as soon as possible to prevent rust. If it is rusted or has poor contact for long time use, you can unscrew the electrode and replace it with a new one.
4. Please do not let the electrophoresis instrument contact the acid solution and the alkaline solution to prevent corrosion or damage of the instrument.

Chapter IV Troubleshooting

Symptoms	Cause	Solution
DNA band blur	DNA degradation	Avoid nuclease contamination during the experiment
	Electrophoresis buffer used multiple times	After the electrophoresis buffer is used for many times, the ionic strength is lowered, the pH value is lowered, and the buffering capacity is weakened, which will affect the electrophoresis effect. Always change the running buffer.

	The electrophoresis conditions used are not suitable	The voltage should not exceed 8V/cm during electrophoresis and the temperature should be less than 30 °C. For large DNA strand, the temperature should be less than 15 °C. Verify that the running buffer used has sufficient buffering capacity.
	Sample overload	Reduce the amount of DNA loaded.
	Salt concentration in sample too high	Remove excess salt by ethanol precipitation before electrophoresis
	Protein contamination	Removed protein by phenol extraction before electrophoresis.
	DNA denaturation	Do not heat sample before electrophoresis, dilute the DNA with 20 mM NaCl buffer.
Irregular DNA band migration	Cos renaturation of the λ /Hind III fragment	Heat the sample at 65 ° C for 5 minutes before electrophoresis and then cool on ice for 5 minutes.
	The electrophoresis conditions used are not suitable	The voltage should not exceed 8V/cm during electrophoresis and the temperature should be less than 40 °C. Always change the running buffer.
	DNA denaturation	Do not heat sample before electrophoresis, dilute the DNA with 20 mM NaCl buffer.
No band or weak band	DNA is not loaded enough	Increase the amount of DNA loaded.
	DNA degradation	Avoid nuclease contamination during the experiment
	DNA runs out of the gel	Shorten electrophoresis time, reduce voltage, and enhance gel concentration.
	For EB-stained DNA, the light source used is not suitable	Use a short wavelength (254 nm) UV source.

DNA band deletion	Small DNA band runs out of the gel	Shorten the electrophoresis time, reduce the voltage, and increase the gel concentration.
	DNA with similar molecular size is difficult to distinguish	Increase the electrophoresis time and use the correct gel concentration.
	DNA denaturation	Do not heat sample before electrophoresis, dilute the DNA with 20 mM NaCl buffer.
	DNA strands are large, conventional gel electrophoresis is not suitable	Analysis on pulse gel electrophoresis.
The sample lane is not straight	The gel is not completely solidified; The comb is skew; Gel has bubbles.	The gel is solidified for at least 30 to 40 minutes. Check the comb. Note that the gel should not have bubbles when making the glue.
High MW bands sharp; Low MW bands smeared	Low gel concentration	Use a suitable concentration of gel. Switch to acrylamide gel for separation.
Gel melt	Temperature is too high	Use the right voltage. Running buffer is used for too many times or incorrectly configured. Reconfigure running buffer
Band smearing	High salt concentration in the sample; Temperature is too high Too much loading; Sample degradation; The sample well is broken when making the gel.	Reduce sample salt concentration. Reduce the voltage or reconfigure the buffer. Increase the thickness of the gel Appropriate loading; Re-extract the sample. Re-made the gel.

Chapter V Transportation and Storage

1. Do not place heavy objects during transportation or storage. When transport, please take it lightly.
2. The packaged product should be stored in a room with a temperature of $-20^{\circ}\text{C} \sim 55^{\circ}\text{C}$, a relative humidity of no more than 93%, no corrosive gas and good ventilation.

Chapter VI Warranty

- 1) The product come with one-year machine warranty free of charge from the date of sold and all-life services.
- 2) This warranty free of charge shall not apply to any product that has been subjected to any following situation. We provide fee-based services for these cases.
 - a. Certificates, warranty cards and invoices cannot be presented.
 - b. Altered invoice.
 - c. Damage caused by accidental factors or disaster; Improper operation and operate not according to the instruction manual.
 - d. Damage caused by self-repair
 - e. Out of the expiration date, while it can still be used after repair.

Schedule: (for reference)

Table 1 Table of correspondence between different DNA size fragment and agarose gel concentration.

Agarose gel concentration (Mass volume ratio)	Resolvable linear DNA fragment size (kb)
0.4 %	5~60
0.7 %	0.8~10
1.0 %	0.4~6
1.5 %	0.2~4
1.75 %	0.2~3
2.0 %	0.1~3

Table 2 Related Instrument and Accessories Ordering Information Sheet

description	Product code
BG-Power300 power supply	100-010-001
BG-Power600i power supply	100-030-001
BG-Power600 power supply	100-020-001
Electrophoresis power cord	2010003001
subMIDI Electrode holder (red)	101-010-011
subMIDI Electrode holder (black)	101-010-012
subMIDI Lower groove (including foot, without electrode holder)	101-010-015
subMIDI Upper cover (including wire fixed base and screw, not include power cord)	101-010-016
PCR electrophoresis package gel casting system	101-010-017
subMIDI gel caster	2020001
Tray 12 x 12cm (BG-subMIDI)	2020002
Tray 6 x 12 cm (BG-subMIDI)	2020003

Tray 12 x 6 cm (BG-subMIDI)	2020004
Tray 6 x 6cm (BG-subMIDI)	2020005
Comb A (1.5mm,2+6/13 well)	2020008
Comb B (0.75mm,6+6/13 well)	2020009
Comb C (1.5mm,8+8/18 well)	2020010
Comb D (0.75mm,8+11/18 well)	2020011
Comb E (1.0mm,11+11/25 well)	2020012
Comb F (2.0mm,3+3/2+3 well)	2020013

BAYGENE BIOTECH COMPANY LIMITED

Address: No. 28, Yuhua Road, Shunyi District, Beijing (No. 7-8, Airport Area B)

Postcode: 101300

Tel: 010-80483100/80483200 010-80483456/80483457

Fax: 010-80482859

Website: www.baygenebiotech.com.cn

Email: info@baygenebiotech.com